

high performance service crane



Captivator 4400w



Advanced safety devices

Amazing crane rating/weight ratio

Continuous improvements in design

Crane structure designed according :

DIN 15018 Standards, lifting class H2-B3.

This rating ensures a working life of 12-15 years in normal usage.

Crane complies ANSI B30.5 - (1989 and Rev. 1992) and OSHA, Title 29, part 1910.180 dtd 07-01-1991.

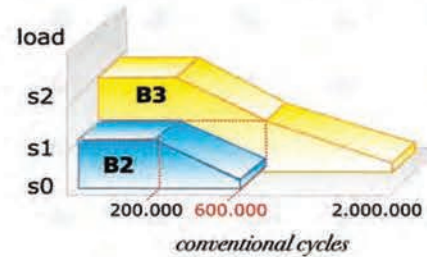
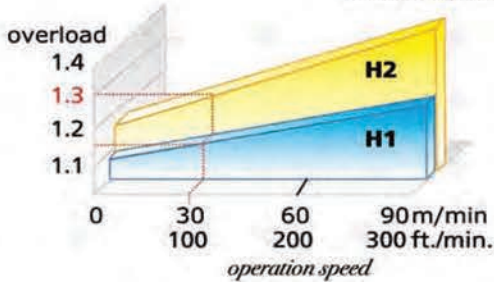

A rating concerning the resistance to overloads while operating is assigned to the metal structures by the letters from H1 to H4. Many manufacturers have a rating H1, while our cranes comply with a rating H2, which is much better because:

if you stay within the curve H1 with an operating speed of 30 m/min, for instance, you will have an overload capacity of 1,15 (15%)

if you stay within the curve H2 considering the same speed, you will have an overload capacity of 1,3 (30%), i.e. DOUBLE than the above one.

A rating is assigned to the metal structures which must last for a long time (such as bridges, cranes, etc.) depending on the requirements they can meet.

As far as cranes are concerned, the DIN 15018 norm assigns a range from B1 to B7.

The truck cranes must comply with a min. rating B2, while our cranes comply with a rating B3, which is much better because:

if you stay within the curve B2, for instance with a definite load S1, you will have a structural life of 200.000 conventional cycles, corresponding to about 50 loading/unloading operations per day for 10 years

if you stay within the curve B3 with the same load S1, you will have a structural life of 600.000 conventional cycles, i.e. three times bigger.

Due to ongoing improvement specifications and dimensions subject to change without notice.

Captivator

high performance service crane

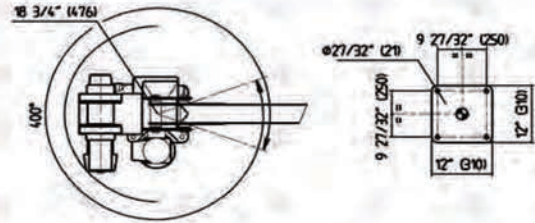
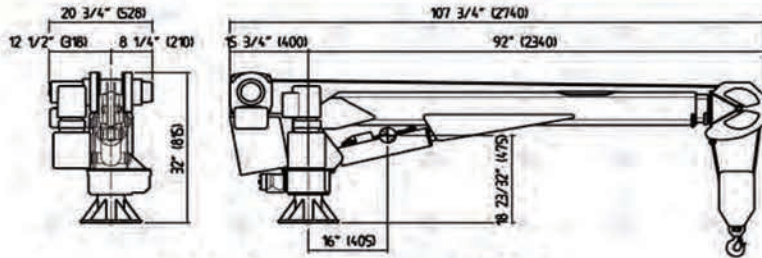

Technical data :captivator4400 W

| | | | | |
|---|----------|----------|--------|-------|
| Crane rating | ft. lbs. | 16,000 | kNm. | 22 |
| Hydraulic extension | ft. | 4' | mm. | 1.200 |
| Manual extension | ft. | 4' 3" | mm. | 1.300 |
| Horizontal extension (from center of rotation) | ft. | 15' 9" | mm. | 4.800 |
| Slewing rotation | | 400° | | |
| Slewing torque | ft. lbs. | 1,600 | kNm. | 2,2 |
| Boom elevation angle | | -5°/+80° | | |
| Max. working pressure | psi. | 2.830 | bar. | 195 |
| Winch : | | | | |
| ° single line capacity | lbs. | 2,250 | Kg. | 1.023 |
| ° double line | lbs. | 4,400 | Kg. | 2.000 |
| Capacity : | | | | |
| ° line pull speed | ft./min. | 11 | m/min. | 3,3 |
| ° rope diameter | in. | 5/16" | mm. | 8 |
| ° rope lenght | ft. | 72' | m. | 22 |
| Crane weight | lbs. | 700 | Kg. | 320 |

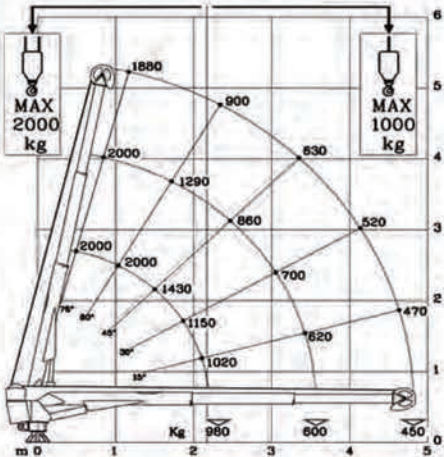
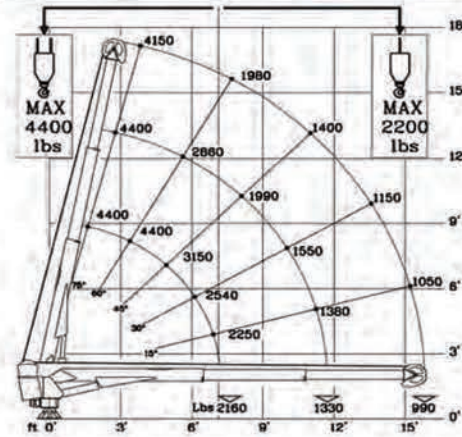

LOAD LIMITING DEVICE

Crane and its operator are protected from overloads by the load limiting device LLD (with transducer). The relevant sensor is incorporated in the boom elevation cylinder and protected from external damage. The LLD is equipped with a LCD screen that shows when 90% and 100% of rated load is reached. Only booming-in and booming down remain operable.

BOOM SYSTEM

Booms are made of extra-high strength, fine grained Swedish steel hexagonally shaped. Stages made of a single piece robot welded. Telescopic hexagonal sections are self-aligning in any condition and at any boom elevation. Rectangular sections made of commercial grade steel, or hexagonal sections made in two parts do not deliver high performances.

BOOM ELEVATION

Crane has -5° to 80° hydraulically powered boom elevation. The elevation cylinder is double acting, incorporating an overcenter (holding + counterbalance + smooth lowering) valve.

REMOTE CONTROL

Crane is equipped with a 26' ft. (8 mt.) length pendant control for operating all the functions. The pendant is connected to the side of the crane column. Radio available (optional).

ROPE SHEAVE

All sheaves are made in anti-friction, high strength weather proof polymer, with maintenance free, sealed bearings.

PLANETARY HOIST WINCH

A heavy duty load brake provides safe dependable control of loads. The winch has a 2,250 lbs. (1.023 Kg.) first layer capacity, its drum houses 72' ft. (22 mt.) of 5/16" (8 mm.) non twisting cable with minimum 11,365 lbs. (5.155 Kg.) breaking strength. Hoist speed for single line operation: 11' ft./min. (3,3 m/min.) Hoist speed for double line operation: 5.5' ft./min. (1,7 m/min.)

SLEWING

Crane has a 400° rotation, hydraulically powered, for uncompromised versatility and ease of use delivering a total coverage of the working area. Positive locking of the slewing system prevents from uncontrolled movements at any time.

ANTI-TWO BLOCK

Crane has an anti-two-block as standard equipment. The preventer protects the crane from accidental two-blocking of the travelling block by making hoist up, boom down and extend out functions inoperable.

TRAVELLING BLOCK

A tip proof, travelling block is supplied. The hook has a capacity of two metric tons, equipped with safety latch and can swivel under load.

PINS WITH BUSHING

Big size pins are nitrated and greased. For lower maintenance and long life time.

OPTIONAL Outrigger system to increase stability and reduce the load on the truck springs while lifting.

Pride Bodies Ltd.
www.pridebodies.com
e mail: sales@pridebodies.com

1 877 726 3447
37 Raglin Pl Cambridge, ON N1R 7J2
(519) 620-8787